

Corte A-A

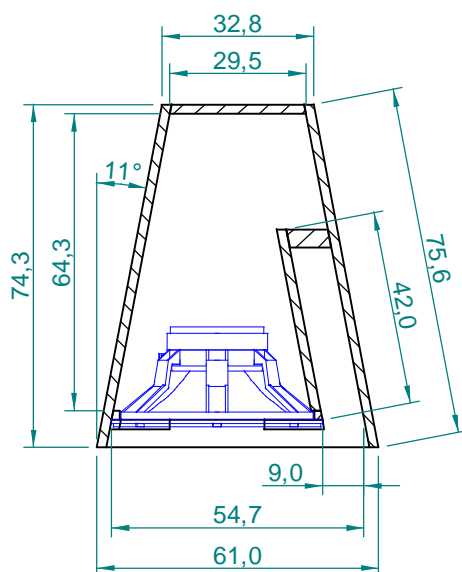

Corte B-B

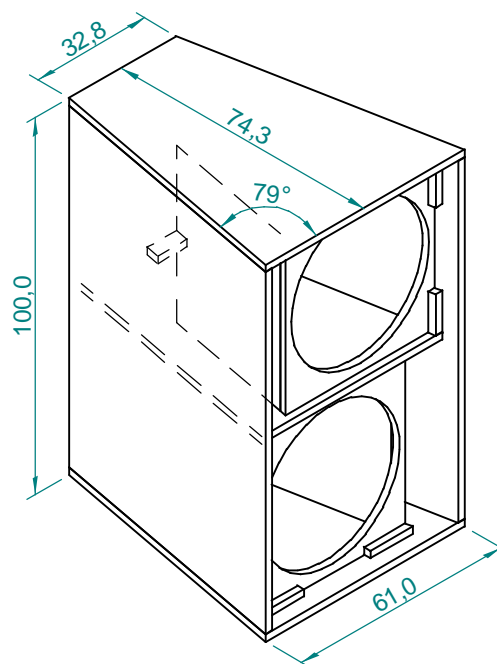

Dimensões em cm.

Caixa de graves, trapezoidal, tipo bass-reflex, para uso em sistemas de PA, utilizando dois falantes de 18".

Relação de Componentes:  
18SW1P subwoofer ou  
WPU1805 ou WPU1807 woofer (2 peças)

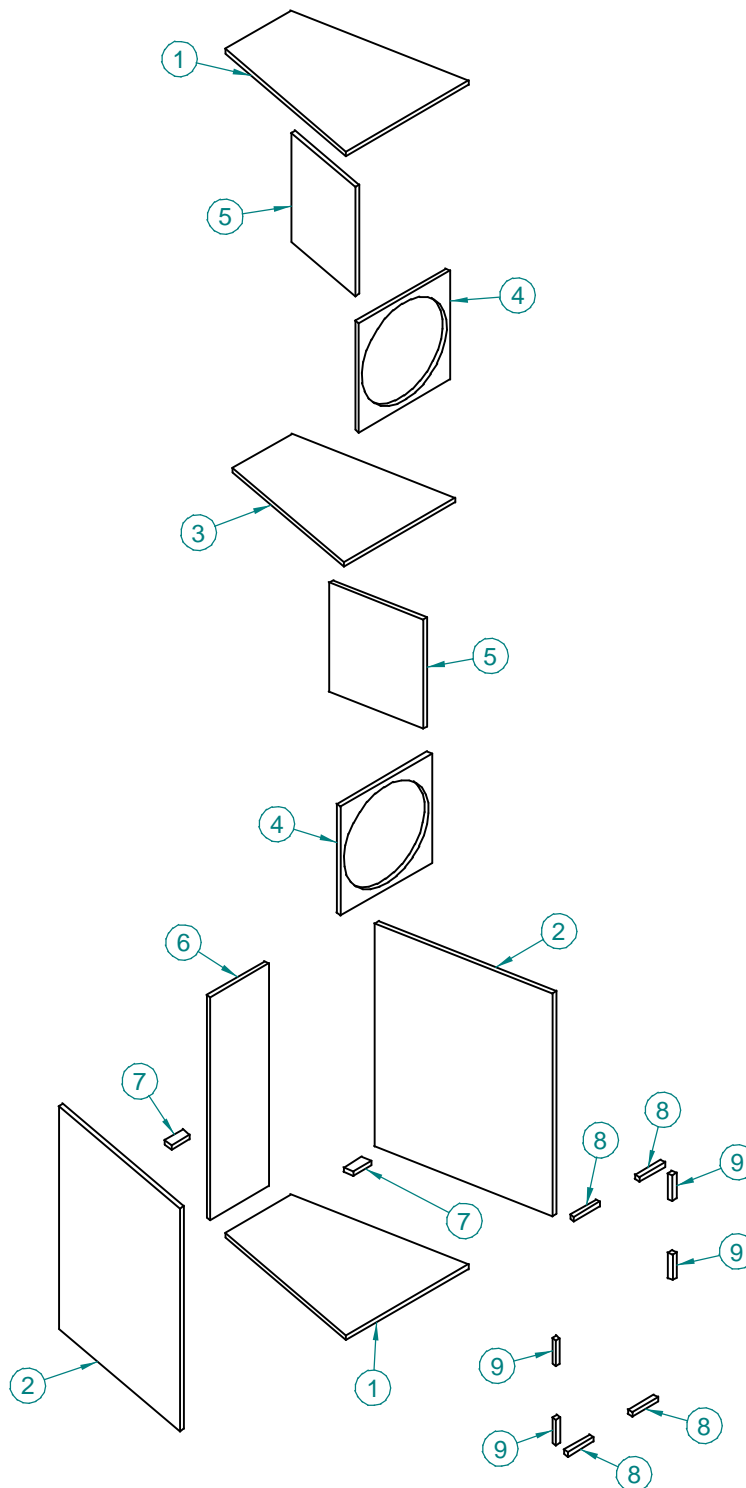

NOTAS:

Volume Interno (Líquido) da Câmara do Falante 18": 97 litros (cada).

## Frequências de Corte:

Falante 18": Inferior: 40 Hz.

Superior: igual à frequência de corte inferior da via seguinte, de acordo com o modelo de caixa escolhido.

Ítem	Qtde	Descrição	Material	Notas
1	2	Base/Tampa	Compensado 20 mm	
2	2	Lateral	Compensado 20 mm	
3	1	Divisória	Compensado 20 mm	
4	2	Painel	Compensado 20 mm	
5	2	Parede do Duto	Compensado 20 mm	
6	1	Fundo	Compensado 20 mm	
7	2	Reforço do Duto	Compensado 20 mm	
8	4	Moldura 1	Compensado 20 mm	
9	4	Moldura 2	Compensado 20 mm	

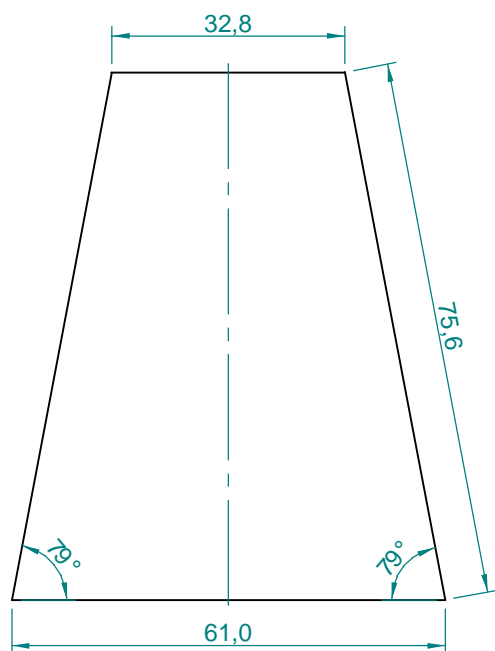

Ítem 1  
Qtde: 2 peças

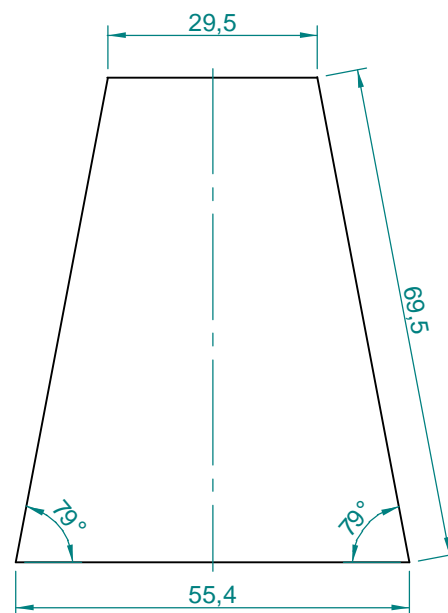

Ítem 3  
Qtde: 1 peça

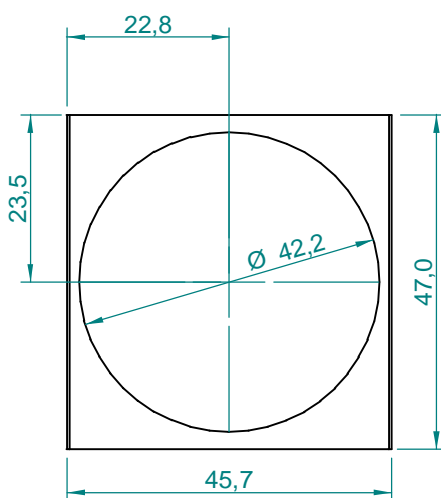

Ítem 4  
Qtde: 2 peças

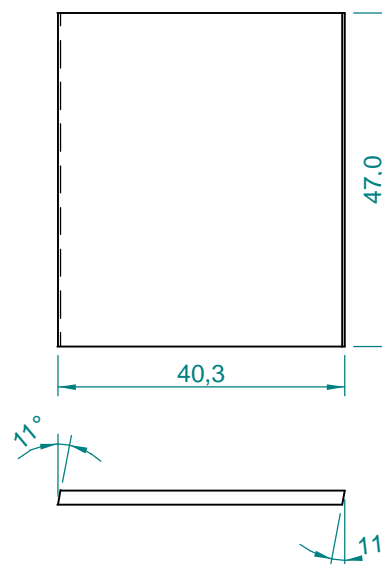

Ítem 5  
Qtde: 2 peças

Dimensões em cm.

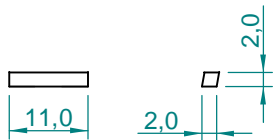

Ítem 9  
Qtde: 2 peças

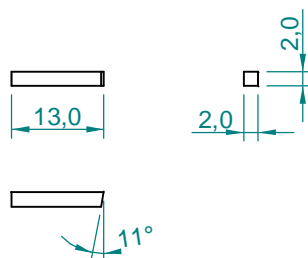

Ítem 8  
Qtde: 2 peças

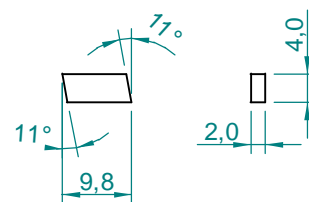

Ítem 7  
Qtde: 2 peças

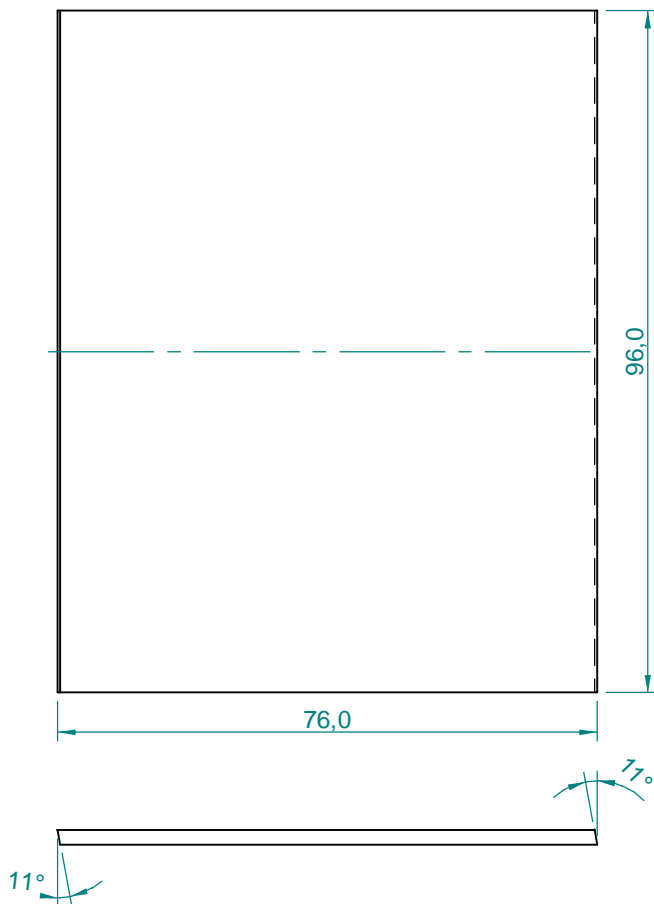

Ítem 2  
Qtde: 2 peças

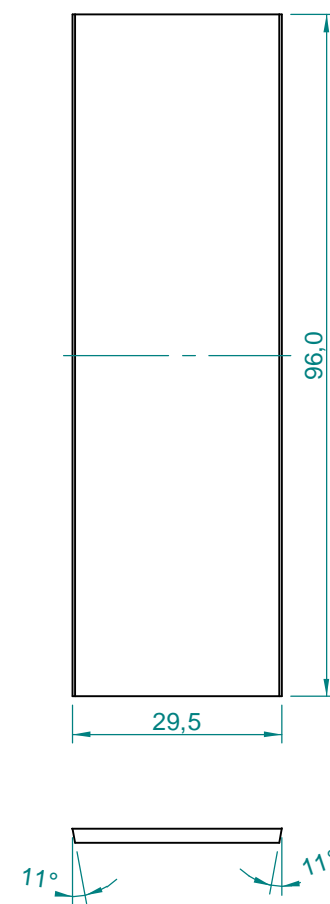

Ítem 6  
Qtde: 1 peça

Dimensões em cm.

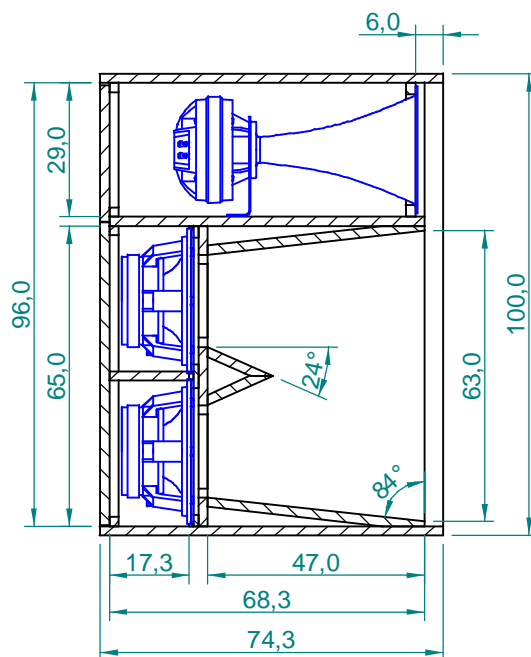
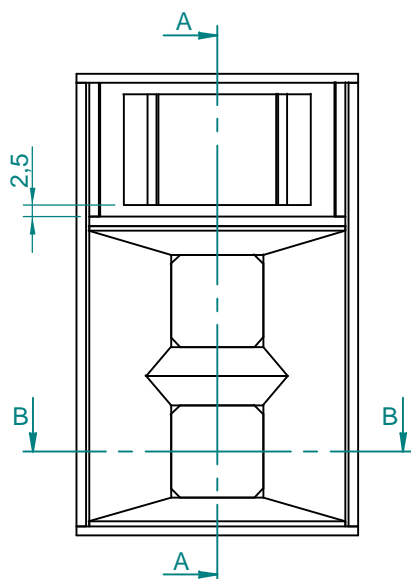

Corte A-A

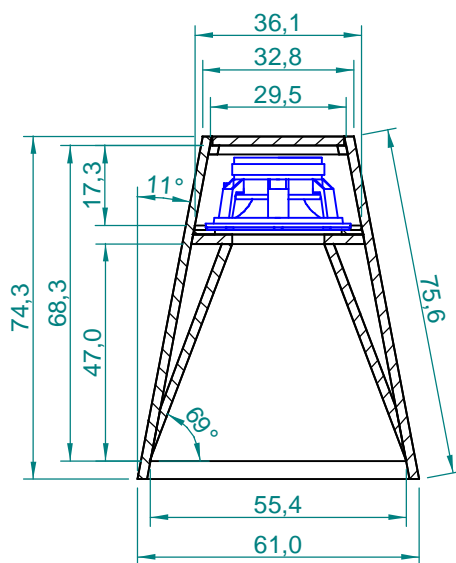

Corte B-B

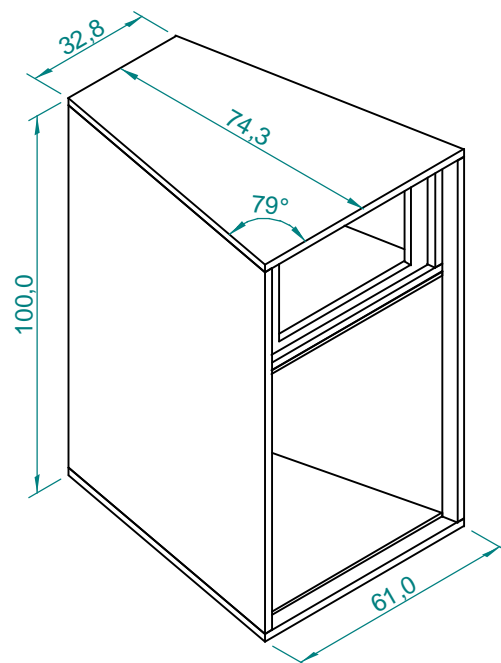

Dimensões em cm.

Caixa trapezoidal, duas vias, tipo corneta, para uso em sistemas de PA, utilizando dois falantes de 12" e um driver de titânio.

Relação de Componentes:  
WPU1206 woofer ou  
12MB1P mid-bass (2 peças)  
D4400Ti ou D3300Ti driver (1 peça)  
HL47-50R corneta (1 peça)

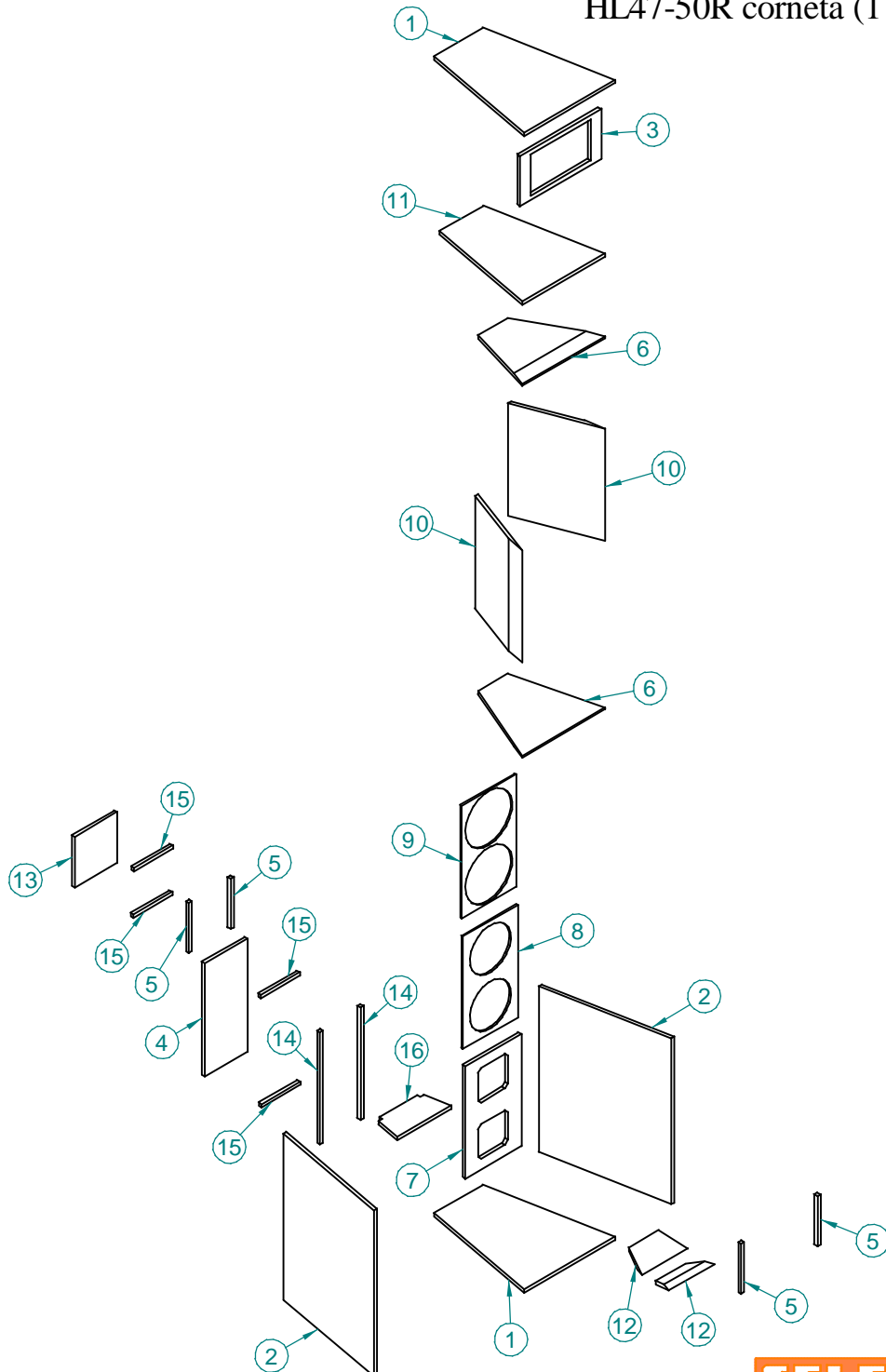

NOTAS:

## Frequências de Corte:

Falante 12": Inferior: 200 Hz.  
Superior: 1.200 Hz.

Driver: Inferior: 1.200 Hz.

Ítem	Qtde	Descrição	Material	Notas
1	2	Base/Tampa	Compensado 20 mm	
2	2	Lateral	Compensado 20 mm	
3	1	Painel 1	Compensado 20 mm	
4	1	Painel Traseiro 1	Compensado 20 mm	
5	4	Moldura 1	Compensado 20 mm	
6	2	Rampa 1	Compensado 20 mm	
7	1	Painel 2	Compensado 20 mm	
8	1	Painel 3	Compensado 10 mm	
9	1	Painel 4	Compensado 10 mm	
10	2	Rampa 2	Compensado 20 mm	
11	1	Divisória 1	Compensado 20 mm	
12	2	Cunha	Compensado 20 mm	
13	1	Painel Traseiro 2	Compensado 20 mm	
14	2	Moldura 2	Compensado 20 mm	
15	4	Moldura 3	Compensado 20 mm	
16	1	Divisória 2	Compensado 20 mm	

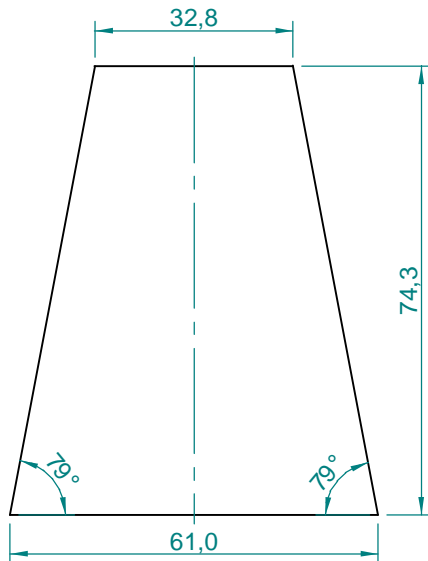
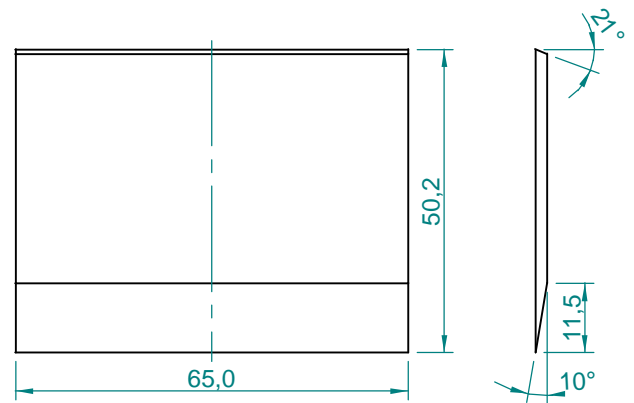
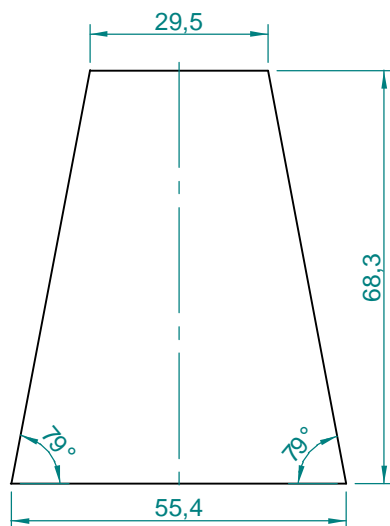
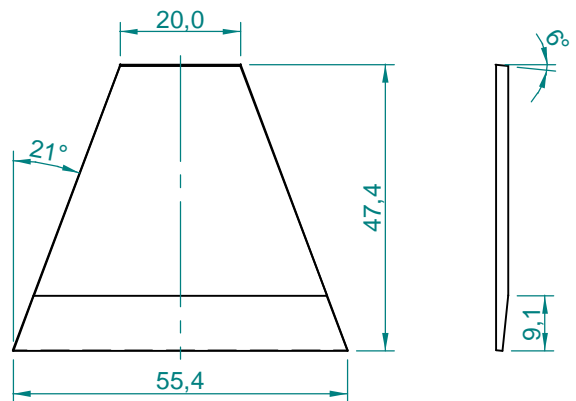
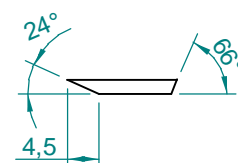
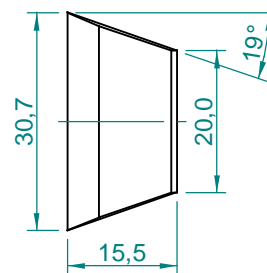
Ítem 1  
Qtde: 2 peçasÍtem 10  
Qtde: 2 peçasÍtem 11  
Qtde: 1 peçaÍtem 6  
Qtde: 2 peçasÍtem 12  
Qtde: 2 peças

Dimensões em cm.

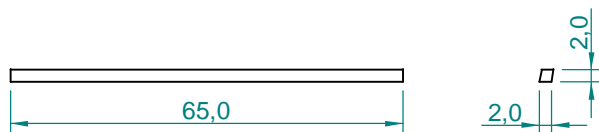

Ítem 14  
Qtde: 2 peças



Ítem 5  
Qtde: 4 peças

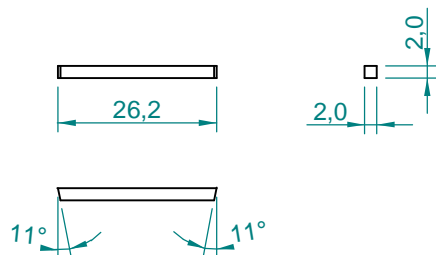

Ítem 15  
Qtde: 4 peças

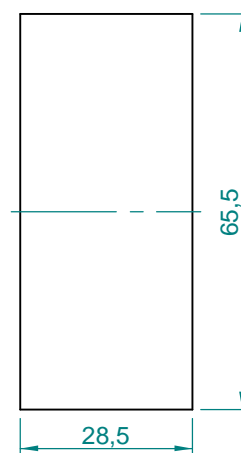

Ítem 4  
Qtde: 1 peça

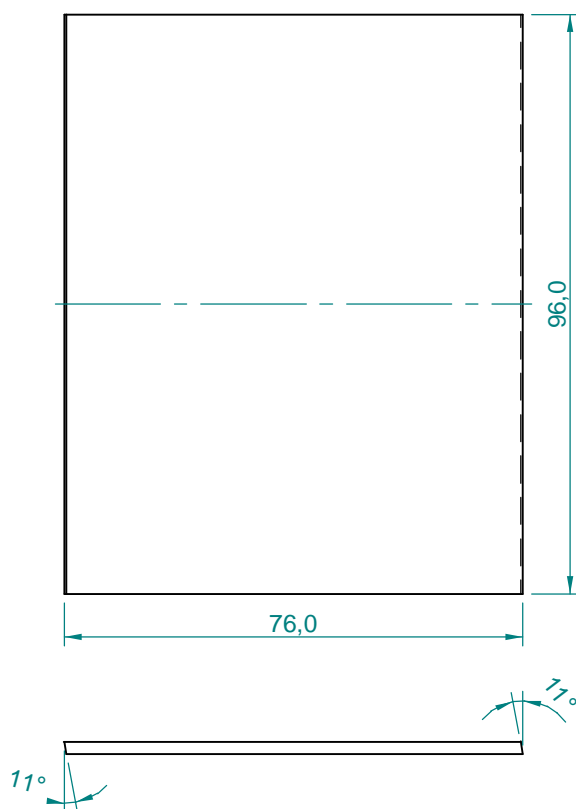

Ítem 2  
Qtde: 2 peças

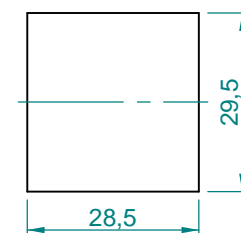

Ítem 13  
Qtde: 1 peça

Dimensões em cm.

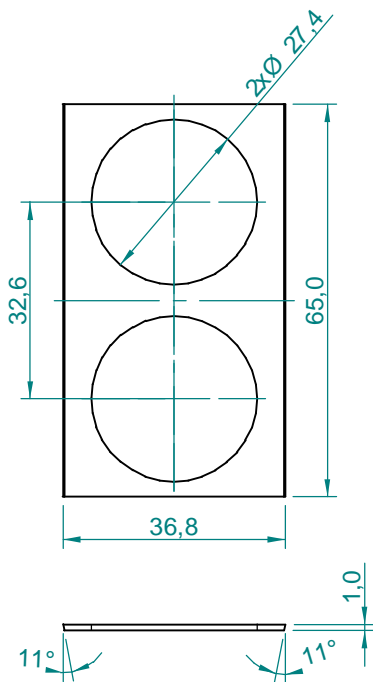

Ítem 8  
Qtde: 1 peça

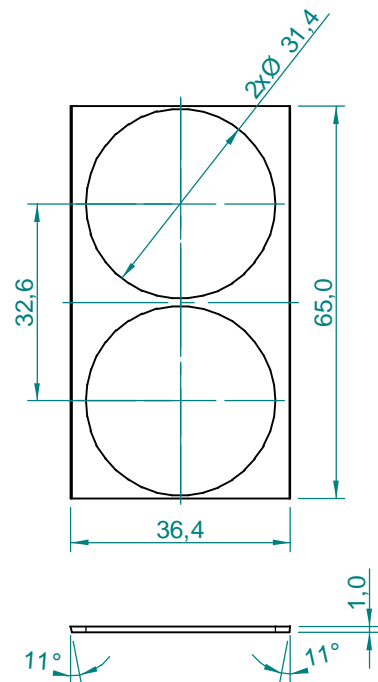

Ítem 9  
Qtde: 1 peça

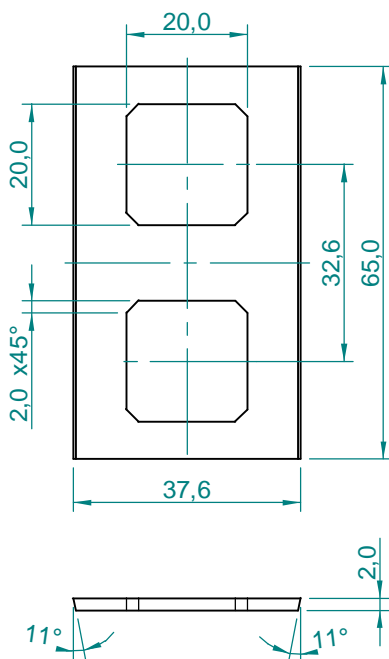

Ítem 7  
Qtde: 1 peça

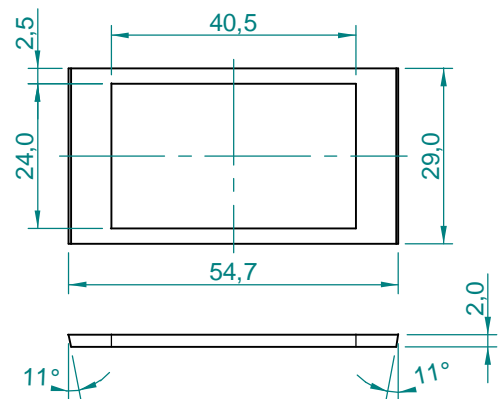

Ítem 3  
Qtde: 1 peça

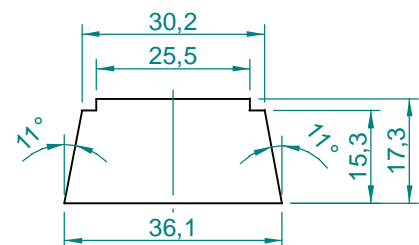

Ítem 16  
Qtde: 1 peça

Dimensões em cm.